

**INSTRUCTION
MANUAL
FRG-7000**

YAESU MUSEN CO., LTD.

TOKYO JAPAN.

TABLE OF CONTENTS

	(Page)
GENERAL DESCRIPTION	1
SPECIFICATIONS	2
CONTROLS AND SWITCHES	3
INSTALLATION	6
OPERATION	7
BLOCK DIAGRAM	10
CIRCUIT DESCRIPTION	10
ALIGNMENT AND MAINTENANCE	13
PARTS LIST	17
WORLD TIME CONVERSION	24
CHART IN HOURS	

“WARNING : TO PREVENT FIRE OR SHOCK HAZARD, DO
NOT EXPOSE THIS APPLIANCE TO RAIN OR MOISTURE.”

COMMUNICATIONS RECEIVER FRG-7000



GENERAL DESCRIPTION

The model FRG-7000 is a high-performance, all solid state, communications receiver designed to cover the entire medium and high-frequency spectrum from 0.25 MHz - 29.9 MHz.

The FRG-7000 features a digital frequency display using large, bright digits for easy viewing. Also included is a 24-hour digital clock for both local and GMT time, with a timing feature for automatic receiver on/off switching.

The FRG-7000 is a triple-conversion superheterodyne receiver, utilizing a synthesized heterodyne oscillator known as the "Wadley Loop System," offering extremely stable receiver performance.

The IF filtering in the FRG-7000 provides a bandwidth of 3 kHz for SSB and CW (at 6 dB down), and 6 kHz for AM (at 6 dB down), thus providing superb rejection of unwanted interference.

The FRG-7000's switchable front-end attenuator and amplified AGC assist in reception under a

variety of conditions, and the continuously variable audio filter provides for minimizing the high or low frequency audio response, as needed. A front panel recording jack plus relay connection jacks on the rear panel provide the flexibility demanded by the discriminating listener.

Plug-in circuit boards are used in the FRG-7000, providing high reliability and ease of servicing. FET's and IC's are used throughout the receiver, providing maximum performance within a compact cabinet.

A built-in AC power supply allows operation from 100/110/117/200/220/234 volts AC, 50/60 Hz. To reduce power consumption, the front panel lamps and digital display may be turned off.

The FRG-7000 is a precision-built instrument. Its performance, versatility, and reliability assure the discriminating listener of many hours of satisfying reception.

SPECIFICATIONS

Frequency Range:

0.25 MHz - 29.9 MHz

Type of Emissions:

AM, SSB (USB or LSB), CW

Sensitivity:

SSB/CW: Better than 0.7 μ V at S/N 10 dB

AM: Better than 2 μ V at S/N 10 dB

Selectivity:

SSB/CW \pm 1.5 kHz (-6 dB), \pm 4 kHz (-50 dB)

AM \pm 3 kHz (-6 dB), \pm 7 kHz (-50 dB)

Stability:

Less than \pm 500 Hz at any 30 minutes after warm-up

Antenna Requirements:

Random wire 0.25 MHz - 1.6 MHz

50 Ohm unbalanced feed 1.6 MHz - 29.9 MHz

Speaker Impedance:

4 ohms

Audio Output:

2 watts

Power Requirement:

100/110/117/200/220/234 volts

AC 50/60 Hz

Power Consumption:

AC 25 VA

Size:

360 (W), 125 (H), 295 (D) mm

Weight:

Approx. 7 kg

SEMICONDUCTOR COMPLEMENT

IC	SN76514N	2		μ PC14305	1
	TA7205AP	1		μ PC14308	2
	MC1416	2		NJM78L05A	1
	MC14011	1	FET	3SK40M	7
	MC14016	1		2SK19GR	8
	MC14027	1	Tr.	2SC372Y	8
	MC14081	1		2SC373	4
	MC14518B	1		2SC535A	1
	MC14519B	1		2SC784(O)	1
	MSM5502	1		2SC828	1
	MSM5592	1		MPS-A13	2
	SN7407N	2	Ge Diode	1S1007	11
	SN74LS00N	2	Si Diode	1S1555	17
	SN74LS90N	1		V06B	8
	SN74LS112N	1	LED	SL-103D	2
	SN74LS390N	1	LED Display	5082-7286	1
	SP8646B	1		5082-7740	5
	μ PA56C	1			
	μ PD546C-1(CPU)	1			

ACCESSORIES

The following accessories are packaged along with your FRG-7000:

- | | | |
|-----|---|-------|
| (1) | MINIATURE PHONE PLUG | 2 ea. |
| | For use in EXT SP or REC jacks. | |
| (2) | PHONE PLUG | 1 ea. |
| | For use with headphones. | |
| (3) | RCA TYPE PLUGS | 2 ea. |
| | For use in control of station equipment through relay jacks on rear panel. | |
| (4) | UHF COAX PLUG | 1 ea. |
| | For connection to HF antenna using coaxial feedline. | |
| (5) | EXTRA FUSES | 2 ea. |
| | 3 amp fuse plus another 1 amp or 0.5 amp fuse, depending on local supply voltage. | |
| (6) | WIRES 3M/10M | 1 ea. |
| | For indoor antennas. | |

CONTROLS AND SWITCHES

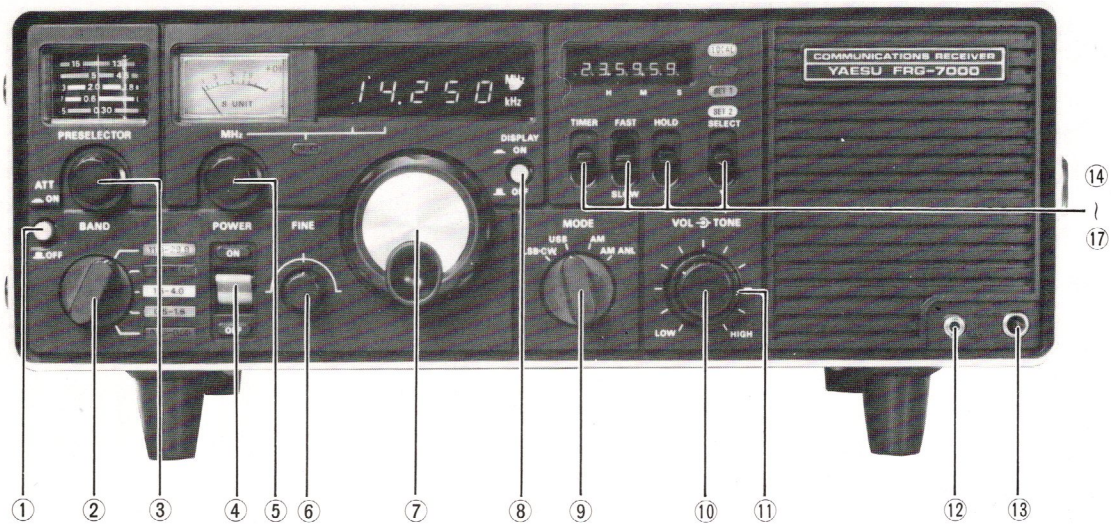

The FRG-7000 has been specifically designed for ease of operation. All controls have been adjusted at the factory to ensure peak performance. The operator may be unfamiliar with the operation of some of the controls, and improper settings thereof may result in poor reception. For this reason, please become thoroughly familiar with the function of every control before attempting to operate the receiver.

FRONT PANEL

(1) ATT (ON, OFF)

The ATT switch activates an attenuator for the receiver front end to minimize overloading under extreme conditions of strong adjacent signals. Maximum receiver sensitivity occurs with the ATT switch OFF.

(2) BAND

The BAND switch has five positions for selecting the proper preselector range for peaking the receiver circuits.

(3) PRESELECT

The preselector peaks the receiver circuits for maximum sensitivity on the frequency being received. The preselector bands are color coded to match the color code of the band switch, and the preselector control should be tuned to the frequency in use by observation of the calibration marks on the color coded scale, and by listening for maximum signal or noise strength from the speaker.

(4) POWER

This is the main on/off switch for the receiver. When it is in the OFF position, the timer circuit will turn the receiver on or off, according to the settings of SET 1 and SET 2 on the digital clock.

(5) MHz

The MHz control selects the 1 MHz band to be tuned for reception. When the control is not set correctly, e.g. between the 6 MHz and 7 MHz segments, the UNLOCK lamp will light to indicate that adjustment is needed.

(6) FINE

This control allows fine tuning of the received frequency.

(7) MAIN TUNING KNOB

This is the main tuning control for the receiver.

(8) DISPLAY (ON, OFF)

For conservation of energy, the front panel digital frequency display and lamps may be switched off with this button. The digital clock is not affected by this control.

(9) MODE (LSB/CW, USB, AM, AM/ANL)

This control selects the desired mode:

- LSB/CW: Lower sideband and CW
- USB: Upper sideband
- AM: Amplitude modulation
- AM/ANL: Amplitude modulation, automatic noise limiter

(10) VOL

This is the main volume control for the receiver.

(11) TONE

This control varies the audio filter so as to emphasize either high or low audio tones.

(12) REC

This jack is for recording purposes, and its output is set to approximately 50 mV, regardless of the setting of the volume control.

(13) PHONES

This is a standard 1/4" headphone jack. When the headphone plug is inserted into the jack, the internal speaker is cut off.

(14) TIMER

With proper setting of the SET 1 and SET 2 positions of the digital clock, placing the TIMER switch in the "down" position will allow automatic ON/OFF switching of the receiver by the digital clock.

(15) FAST/SLOW

This lever switch is used for setting the digital clock. The fast speed is used for rapid advancement of the indicated time, and the slow speed is used for the final, fine adjustment.

(16) HOLD

This lever switch will lock the digital clock on the indicated time. This switch is useful for alignment of the GMT and LOCAL indications, and also for time setting if the FAST/SLOW control advances the time too far.

(17) SELECT

Each time the SELECT switch is pressed downward, the digital clock selection lamps are switched, corresponding to the change in the clock function. If the local time is being displayed (LOCAL lamp lighted), pressing the SELECT switch will cause the SET 1 lamp to light, and the clock will now display the time which has been programmed into the SET 1 position. Another press of the SELECT switch will cause SET 2 to be displayed, etc.

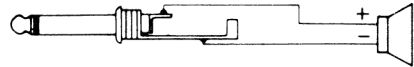

**Speaker Connection
Via Headphone Plug**

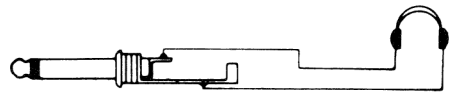

Phone Plug

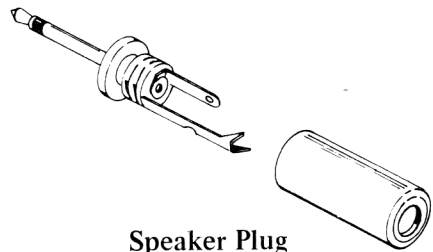

Speaker Plug

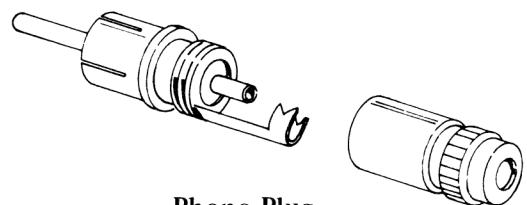
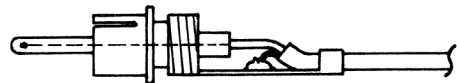

Phono Plug

REAR PANEL

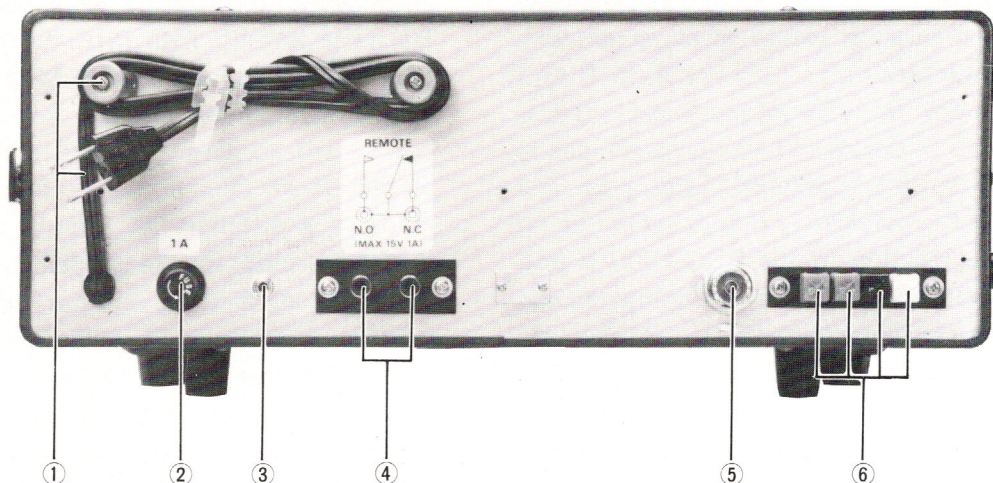

(1) POWER CORD AND CORD HOLDER

The power cord may be wrapped around the cord holder for packing purposes.

(2) FUSE

For 100/110/117 volt operation, a 1 amp fuse should be installed here. For 200/220/234 volt operation, a 1/2 amp fuse should be installed. BE CERTAIN TO USE A FUSE OF THE PROPER RATING WHEN REPLACING FUSES.

(3) EXT SP

This jack is for connection of an external speaker. The impedance is 4 ohms, and insertion of a plug into this jack disables the internal speaker.

(4) REMOTE (N.O./N.C.) (N.O. = Normally Open; N.C. = Normally Closed)

These two phono jacks are used for switching peripheral station equipment such as tape recorders, etc. When the TIMER switch is activated, and the clock passes the SET 1 time, the relay is activated. When the SET 2 time is passed, the relay returns to its normal state. With the TIMER switch off, the relay is in its normal state. The relay contacts are rated at 15 V at 1A.

(5) SW2

This is a standard UHF connector for coax-fed shortwave antennas.

(6) SW1, BC, E, MUTE

SW1 is a low-impedance connection for a random-length shortwave antenna.

BC is a high-impedance connection for a random-length shortwave antenna.

E is a ground connection.

MUTE is a connection for muting FRG-7000, as, for example, with an external standby switch. Shorting the MUTE terminal to ground will mute the receiver.

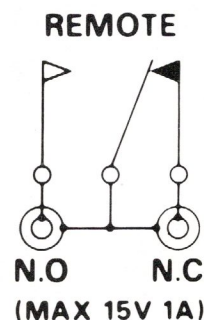

INSTALLATION

Carefully remove FRG-7000 from its carton, and inspect it for any signs of physical damage. Should any damage be observed, immediately notify the shipping company, stating the damage in detail. Save the carton and the packing material for possible future use.

LOCATION

In general, the location of the FRG-7000 is not critical. However, it is recommended that excessively warm locations be avoided.

The FRG-7000 is supplied with a multi-voltage power transformer (export model only). Thus, when moving to an area where the supply voltage is different from your accustomed supply voltage, your FRG-7000 may still be used. Before commencing operation initially, **BE SURE THAT THE VOLTAGE MARKED ON THE REAR OF THE RECEIVER AGREES WITH THE LOCAL AC SUPPLY VOLTAGE.**

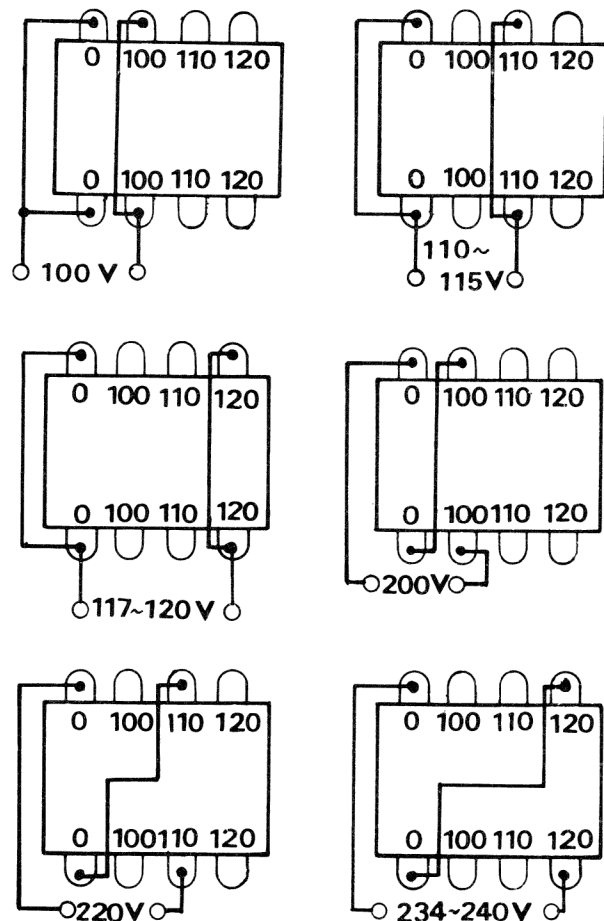

Fig.1 Transformer Primary Wiring

CAUTION

PERMANENT DAMAGE WILL RESULT IF IMPROPER AC SUPPLY VOLTAGE IS APPLIED TO THE RECEIVER. THE WARRANTY DOES NOT COVER DAMAGE CAUSED BY IMPROPER AC SUPPLY VOLTAGE.

Should it become necessary to adapt the FRG-7000 to a different AC supply voltage, refer to the chart below for the proper connections. After modification, make a notation on the rear panel regarding the AC supply voltage in use.

If fuse substitution is required, be certain to use a fuse of the proper rating. For 100 - 117 volt operation, use a 1 amp fuse; for 200 - 234 volts, use a 1/2 amp fuse. The fuse holder is located on the rear apron. The counter unit also has a fuse of 3 amps (for all voltages). This fuse is installed inside the cabinet.

CAUTION

BE CERTAIN TO USE A FUSE OF THE PROPER RATING. WARRANTY DOES NOT COVER DAMAGE CAUSED BY USE OF AN IMPROPER FUSE.

ANTENNA AND GROUND

The antenna is the most important part of the communications receiver installation. The FRG-7000 is designed for use with a random-length antenna for 0.25 MHz - 1.6 MHz, and the antenna should be as long and high as possible. For 1.6 MHz - 29.9 MHz, maximum performance is secured through the use of a resonant antenna having an impedance of 50 to 75 ohms at the operating frequency. A center-fed dipole antenna cut for the desired frequency will easily satisfy this requirement, and it should be fed with coaxial cable. The length of a center-fed dipole can be determined by the formula

$$\text{Length (feet)} = 468/\text{frequency (MHz)}$$

$$\text{Length (meters)} = 142.5/\text{frequency (MHz)}$$

The FRG-7000 should be connected to a good earth ground. The ground lead should be of a heavy-gauge braided cable or wire, and should be connected to the terminal marked E on the rear panel of the receiver.

OPERATION

FREQUENCY SELECTION

The operating frequency is read directly from the digital display. All digits of the operating frequency are displayed, with resolution to 1 kHz. The main tuning dial provides rapid frequency change, and the fine tuning control allows ± 2.5 kHz adjustment for precise zeroing on the desired station.

The main tuning dial tunes a 1 MHz range, and thus controls the last three digits of the displayed frequency (000 to 999). For setting the digital display to the desired frequency, rotate the MHz control until the desired MHz range is reached, then rotate the main tuning dial to set the last three digits of the displayed frequency. The MHz control is somewhat critical in adjustment, and care should be taken to adjust it so that the UNLOCK lamp is not illuminated.

PRESELECTOR OPERATION

For peaking the receiver circuits for maximum sensitivity on the desired frequency, the preselector must be tuned to that frequency. The BAND switch should be rotated so that the preselector band appropriate for the operating frequency is selected. For example, for peaking for reception on 6.910 MHz, the 4.0 MHz - 11.0 MHz (green) range should be selected.

Next, rotate the PRESELECTOR control and observe the color-coded calibration of the preselector dial drum. The calibration marking should correspond to the operating frequency; precise adjustment is made by peaking the noise level or signal strength at the speaker, while carefully adjusting the PRESELECTOR control. The ATT switch should be OFF during peaking of the preselector.

Refer to Table 1 for details regarding the various switch and controls.

	Frequency	PRESELECT	Main Dial	BAND	MODE
Amateur	kHz 1,910	2.0 1.8	1,910 MHz	1.6 - 4.0	LSB · CW
	3,525	3.6 3.3	3,525 //	1.6 - 4.0	LSB · CW
	7,050	8 7	7,050 //	4.0 - 11.0	LSB · CW
	14,175	15 13	14,175 //	11.0 - 29.9	USB
	21,225	23 20	21,225 //	11.0 - 29.9	USB
	28,850	30 26	28,850 //	11.0 - 29.9	USB
Medium Wave	590	0.6	590 kHz	0.5 - 1.6	AM or AM/ANL
	980	1.0 0.8	980 //	0.5 - 1.6	AM or AM/ANL
	1,170	1.2 1.0	1,170MHz	0.5 - 1.6	AM or AM/ANL
WWV/JJY	2,500	2.6 2.3	2,500MHz	1.6 - 4.0	AM or AM/ANL
	5,000	5 4	5,000 //	4.0 - 11.0	AM or AM/ANL
	10,000	11 10 9	10,000 //	4.0 - 11.0	AM or AM/ANL
	15,000	17 15	15,000 //	11.0 - 29.9	AM or AM/ANL
Short Wave	3,925	4.0 3.6	3,925MHz	1.6 - 4.0	AM or AM/ANL
	5,980	6	5,980 //	4.0 - 11.0	AM or AM/ANL
	9,715	10 9	9,715 //	4.0 - 11.0	AM or AM/ANL
	11,705	12 11	11,705 //	11.0 - 29.9	AM or AM/ANL
	15,120	17 15	15,120 //	11.0 - 29.9	AM or AM/ANL
	17,880	20 17	17,880 //	11.0 - 29.9	AM or AM/ANL
	21,550	23 20	21,550 //	11.0 - 29.9	AM or AM/ANL

Table 1

BROADCAST BAND (0.5 MHz - 1.6 MHz) OPERATION

Special caution should be observed when attempting broadcast band reception, as the MHz control may appear to select more than one range for the segment of the band below 1 MHz. Use only the position of the MHz control immediately adjacent to the 1.0 MHz - 2.0 MHz band.

SHORTWAVE BROADCAST RECEPTION

International shortwave broadcast stations use the AM mode. Turn the POWER switch ON (TIMER switch OFF), place the MODE switch in the AM position, and select the desired frequency as described in the previous section. The VOLUME control should be adjusted for a comfortable listening level. The TONE control may be adjusted to provide the desired fidelity, and the FINE control will allow precise adjustment of the received frequency.

In the presence of extremely strong signals, the ATT switch may be placed in the ON position to prevent overload of the receiver front end. Should impulse noise be present, the MODE switch may be placed in the AM/ANL position.

AMATEUR BAND RECEPTION

SSB Voice Signals:

Virtually all amateurs use lower sideband (LSB) on the frequency bands below 7.3 MHz, and upper sideband (USB) above 14.0 MHz. Set the MODE switch to USB or LSB, as appropriate, and rotate the main tuning dial until a signal is clearly heard. The FINE control is extremely useful when tuning in SSB signals. The VOLUME and TONE controls should be adjusted for the clearest reception level.

CW (Morse Code Signals):

Amateur and commercial Morse Code transmissions may be received by placing the MODE switch in the LSB/CW position, and tuning the main dial and FINE controls for the desired listening tone.

Power Switch	Timer Switch		RECEIVER		REMOTE	
			SET-1	SET-2	N.O.	N.C.
OFF	OFF	OFF	OFF	OFF	OPEN	CLOSE
ON	OFF	ON	ON	ON	OPEN	CLOSE
OFF	ON	OFF	ON	—	CLOSE	OPEN
			—	OFF	OPEN	CLOSE
ON	ON	ON	OFF	—	CLOSE	OPEN
			—	ON	OPEN	CLOSE

Table 2

DIGITAL CLOCK OPERATION

The built-in digital clock will provide display of both your local time and Greenwich Mean Time (GMT). When the FRG-7000 is initially plugged in, the clock will indicate "00.00.00" and begin counting the seconds as they pass.

To set the clock to your local time, place the SELECT switch in the LOCAL position. Then use the FAST and SLOW switches to set the clock to the proper time. If desired, the clock may be set to some precise hour (for example, 11.00.00), and then the HOLD switch should be activated to hold the time at that point. When the time reaches exactly 11.00.00, release the HOLD switch, and the clock will resume counting. This technique is recommended for precise time calibration to a time standard such as WWV or JJY.

For setting to GMT time, it is recommended that the HOLD switch technique be used. Align the LOCAL time to a suitable point (e.g. 16.00.00) and activate the HOLD switch. Place the SELECT switch in the GMT position, and use the FAST and SLOW switch to calibrate the GMT clock with the GMT appropriate for the LOCAL time being held (e.g. 16.00.00 Eastern Standard Time = 21.00.00 GMT). Release the HOLD switch to start both clocks simultaneously.

The HOLD switch will freeze the time on both clocks. The FAST and SLOW switch will advance only the clock being displayed. The clock is operative as long as the FRG-7000 is plugged in.

TIMER OPERATION

The SET 1 and SET 2 positions of the SELECT switch may be set to provide automatic ON and OFF control of the FRG-7000. For example, if a favorite program starts at 0730 local time, 07.30.00 may be stored in the SET 1 position for automatically turning the receiver on at that time. When it is desired to turn the receiver off automatically, that time may be stored in the SET 2 position. The TIMER circuitry may also be used for controlling peripheral equipment such as a tape recorder, as the timer relay actuates the REMOTE jacks on the rear apron.

The timer circuitry has the effect of switching the condition of the receiver as determined by the POWER switch. That is, when the POWER switch is OFF, and the TIMER switch ON, the receiver will be OFF until the SET 1 time. Between the SET 1 and SET 2 times, the receiver will be ON, and between the SET 2 and SET 1 times the receiver will again be OFF.

When the POWER switch is in the ON position, these relations are reversed. That is, with the POWER switch ON, and the TIMER switch ON, the receiver will be ON until the SET 1 time. From the SET 1 time until the SET 2 time, the receiver will be OFF, and after the SET 2 time the receiver will be ON until the SET 1 time.

The REMOTE contacts are controlled by the TIMER relay. In the period between the SET 1 and SET 2 times, the normally open (N.O.) jack will be CLOSED, and the normally closed (N.C.) jack will be OPEN. With the TIMER switch OFF, regardless of the position of the POWER switch, the jacks are in their "normal" states.

For example, if you must be away from your station, but want to record a program, proceed as follows: preset the receiver to the proper frequency and peak the preselector, etc. Connect the FRG-7000 REC jack to the recording input of the tape recorder, and connect the tape recorder "footswitch" jack to the REMOTE N.O. jack. Align the SET 1 time to the start of the program, and the SET 2 time to the end of the program. Place the POWER switch in the OFF position, and the TIMER switch ON. Place the tape recorder in the record condition; it should not operate because the REMOTE N.O. jack is open. When the SET 1 time is reached, the FRG-7000 will turn on, the tape recorder will be activated, and both will operate until the SET 2 time (the end of the program).

CIRCUIT DESCRIPTION

The block diagram will provide you with a better understanding of this receiver. Basically, the FRG-7000 is a triple-conversion superheterodyne receiver utilizing a synthesized local oscillator for both the first and second mixers. The result is drift-free VFO operation.

The signal from the antenna is fed through the RF attenuator to the gate of the FET RF amplifier Q₁₀₁ (3SK51-03). The amplified signal is fed through a low-pass filter (cutoff frequency 35 MHz) to the first balanced mixer, consisting of Q₁₀₂ and Q₁₀₃ (both 2SK19GR), where the incoming signal is mixed with a signal from the heterodyne oscillator. The first heterodyne oscillator, Q₃₀₁ (2SC7840), provides a signal varying between 55.5 and 84.5 MHz.

A 52.5 MHz heterodyne signal is produced as follows: the synthesized oscillator Q₅₀₁ (2SC372Y) generates a 1 MHz signal, which is then fed to harmonic generator D₅₀₁ - D₅₀₂ (both 1S1007). This produces a series of harmonics from 3 to 32 MHz. This signal is fed to the first pre-mixer, Q₂₀₁ (SN76514), where the 55.5 MHz - 84.5 MHz and 3 MHz - 32 MHz signals are mixed, producing a 52.5 MHz signal.

The 52.5 MHz output signal from Q₂₀₁ is fed to the second pre-mixer Q₂₀₂ (3SK51-03), where the 52.5 MHz signal is mixed with a 63.2 MHz signal generated by Q₂₀₇ (2SK19GR), producing a 10.7 MHz IF signal.

The 10.7 MHz IF signal passes through a 10.7 MHz ceramic filter and is amplified by Q₂₀₃ (2SK19GR) and fed to mixer Q₂₀₄ (SN76514), where the 10.7 MHz signal is mixed with a 63.2 MHz signal generated by Q₂₀₇, producing a filtered 52.5 MHz signal.

The 52.5 MHz signal is then amplified by Q₂₀₅ (3SK51-03) and Q₂₀₆ (2SK19GR), and returned to the RF UNIT as the heterodyne signal for the second mixer, Q₁₀₅ (2SK19GR). A portion of the output signal from Q₂₀₆ is rectified by D₂₀₂ (both 1S1007). The DC voltage is then amplified by Q₂₁₀ (2SC372Y) and fed to the LOCK indicator driver Q₂₀₉ (2SC372Y), which turns the LOCK lamp PL₃ on when the synthesizer is unlocked.

The 54.5 MHz - 55.5 MHz signal is mixed with the 52.5 MHz heterodyne signal by Q₁₀₅ (2SK19GR), resulting in a 2 MHz - 3 MHz IF

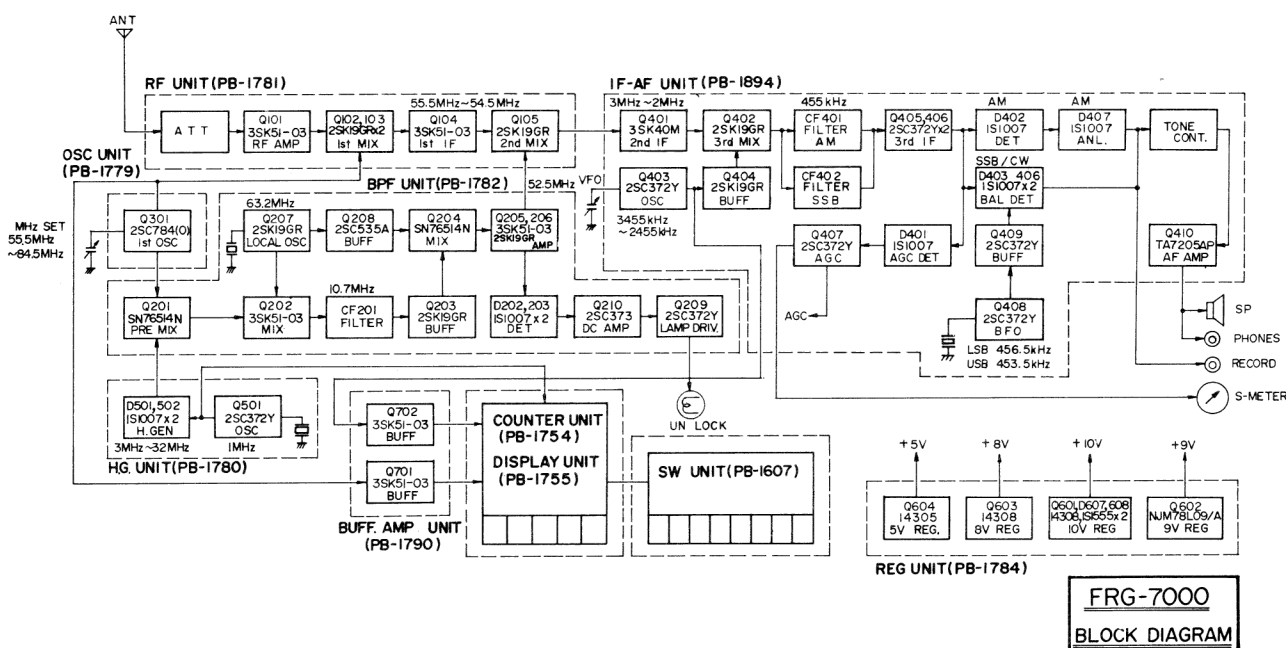

BLOCK DIAGRAM

signal. This IF signal is amplified by Q₄₀₁ (3SK40M) and fed to a third mixer Q₄₀₂ (2SK19GR), where the IF signal is mixed with a 2455 kHz - 3455 kHz heterodyne signal, producing a 455 kHz third IF signal. The 2455 kHz - 3455 kHz heterodyne signal is generated by VFO oscillator Q₄₀₃ (2SC372Y) and fed through buffer amplifier Q₄₀₄ (2SK19GR) to Q₄₀₂. The 455 kHz IF signal is fed through a ceramic filter, CF-401, for AM, or CF-402 for SSB and CW, to eliminate adjacent-frequency interference.

The signal is then amplified by the third IF amplifier Q₄₀₅ and Q₄₀₆ (both 2SC372Y), and fed to the appropriate detector. The AM signal is detected by diode detector D₄₀₂ (1S1007).

Balanced demodulator D₄₀₃ - D₄₀₆ (all 1S1007) is used for the detection of SSB and CW signals. The carrier signal for SSB and the beat frequency signal for CW (generated by BFO oscillator Q₄₀₈ (2SC372Y)), are fed to the balanced demodulator through buffer amplifier Q₄₀₉

(2SC372Y). The MODE switch shifts the BFO frequency for reception of an LSB or USB signal.

The output from the detectors is amplified by Q₄₁₀ (TA7205AP) for delivery to the speaker.

A portion of the output from the last IF amplifier Q₄₀₆ is fed to the AGC (Automatic Gain Control) rectifier D₄₀₁ (1S1007). The rectified AGC voltage is then amplified by AGC amplifier Q₄₀₇ (2SC372Y) and fed to Q₁₀₁, Q₄₀₁, and Q₄₀₅ to control the gain of these stages automatically according to the strength of the received signal. Thus, the receiver output is not affected by variations in signal strength which may be caused by phase shift on the incoming signal. The S-meter is placed in the emitter circuit of Q₄₀₇, in which the emitter current changes in accordance with the incoming signal strength.

The 55.5 MHz - 84.5 MHz and 2455 kHz - 3455 kHz signals are amplified, respectively, by buffer amplifiers Q₇₀₁ and Q₇₀₂ (both 3SK51-03), and fed to the counter to display the received frequency.

FREQUENCY f	1ST OSC fo ₁	1ST IF (fo ₁ - fi ₁) fi ₁	REF FREQ (1MHz × n) fh	2ND OSC (fo ₁ - fh) fo ₂	2ND IF (fi ₁ - fo ₂) fi ₂	3RD OSC fo ₃	3RD IF (fo ₃ - fi ₂) fi ₃
500kHz	55.5MHz	55.0MHz	3MHz	52.5MHz	2,500kHz	2,955kHz	455kHz
1,500	56.5	55.0	4	"	2,500	2,955	"
2,500	57.5	55.0	5	"	2,500	2,955	"
3,500	58.5	55.0	6	"	2,500	2,955	"
4,500	59.5	55.0	7	"	2,500	2,955	"
5,500	60.5	55.0	8	"	2,500	2,955	"
6,500	61.5	55.0	9	"	2,500	2,955	"
7,500	62.5	55.0	10	"	2,500	2,955	"
8,500	63.5	55.0	11	"	2,500	2,955	"
9,500	64.5	55.0	12	"	2,500	2,955	"
10,000	65.5	55.5	13	"	3,000	3,455	"
11,000	66.5	55.5	14	"	3,000	3,455	"
12,000	67.5	55.5	15	"	3,000	3,455	"
13,000	68.5	55.5	16	"	3,000	3,455	"
14,000	69.5	55.5	17	"	3,000	3,455	"
15,000	70.5	55.5	18	"	3,000	3,455	"
16,000	71.5	55.5	19	"	3,000	3,455	"
17,000	72.5	55.5	20	"	3,000	3,455	"
18,000	73.5	55.5	21	"	3,000	3,455	"
19,000	74.5	55.5	22	"	3,000	3,455	"
20,000	75.5	55.5	23	"	3,000	3,455	"
21,100	76.5	55.4	24	"	2,900	3,355	"
22,200	77.5	55.3	25	"	2,800	3,255	"
23,300	78.5	55.2	26	"	2,700	3,155	"
24,400	79.5	55.1	27	"	2,600	3,055	"
25,500	80.5	55.0	28	"	2,500	2,955	"
26,600	81.5	54.9	29	"	2,400	2,855	"
27,700	82.5	54.8	30	"	2,300	2,755	"
28,800	83.5	54.7	31	"	2,200	2,655	"
29,900	84.5	54.6	32	"	2,100	2,555	"

Table 3 Frequency Relationship

The counter unit utilizes a 4-bit microcomputer unit (CPU) to display the frequency being received. The CPU also drives the digital clock, which displays both local and GMT time. The clock section of the CPU controls the timer function for ON/OFF control of the receiver and peripheral station equipment.

The regulated power supply consists of four regulators: Q₆₀₁ (14308), Q₆₀₂ (NJM 78L09A), Q₆₀₃ (14308), and Q₆₀₄ (14305), to deliver stabilized voltages of 10V, 9V, 8V, and 5V to various circuits in the receiver.

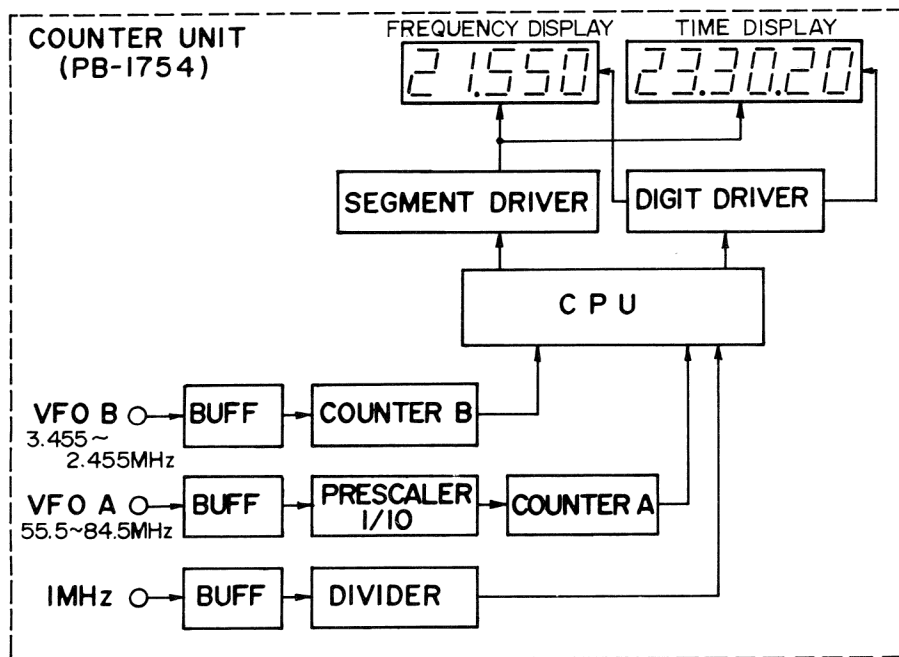

MAINTENANCE & ALIGNMENT

GENERAL

The FRG-7000 has been carefully aligned and tested at the factory prior to shipment, and, with normal usage, it should not require other than the usual attention given to electronic equipment. Service or replacement of a major component many entail substantial realignment; under no circumstances, however, should realignment be attempted unless the operation of the receiver is fully understood and the malfunction has been definitely attributed to misalignment rather than component failure. Service work should be performed by experienced personnel using proper test equipment.

(1) Local Oscillator T_{207}

Connect a VTVM between TP_{202} and TP_{204} (ground). Adjust T_{207} for 0.6V RMS as indicated on the VTVM. Connect a frequency counter to TP_{202} , and make sure that the output frequency is 63.2 MHz.

(2) Output level $T_{201} - T_{206}$

Connect a VTVM between TP_{108} and TP_{109} (ground). Set the FRG-7000 MHz control to 29 MHz. Carefully adjust the MHz control for a maximum VTVM reading. Then peak $T_{201} - T_{201}$ for a maximum VTVM reading.

(3) Harmonic generator TC_{501}

Connect a frequency counter between TP_{502} and TP_{501} (ground), and adjust TC_{501} for a reading of 1 MHz. The output voltage at TP_{502} should be approximately 0.2V RMS.

(4) Oscillator Unit T_{301}, TC_{301}

Connect a frequency counter between TP_{107} and TP_{104} (ground). Set the FRG-7000 MHz control to the fully counterclockwise position. Adjust T_{301} for a reading of 54.0 MHz on the counter. Set the MHz control to the fully clockwise position, and adjust TC_{301} for a reading of 85.2 MHz on the counter. Repeat the above adjustments, if necessary, until the UNLOCK lamp turns off at every 1 MHz incremental advancement of the MHz control.

(5) VFO Frequency T_{403}, TC_{403}

This alignment should be performed after the receiver has been allowed to warm up 30 minutes. Connect a frequency counter between TP_{402} and TP_{404} (ground). Set the main tuning knob to the fully clockwise position, and adjust T_{403} for a reading of 2380 kHz on the counter. Set the main tuning knob next to the fully counterclockwise position, and adjust TC_{403} for a counter reading of 3480 kHz. Repeat this adjustment, if necessary, until complete tracking is accomplished. The output voltage at TP_{402} should be 0.3V - 0.6V RMS.

(6) Second IF Alignment $T_{401}, T_{402}, TC_{401}, TC_{402}$

Connect a signal generator between TP_{105} and TP_{106} (ground). Set the MODE switch to the AM position, and set the signal generator output frequency to 2.1 MHz (the FRG-7000 display should indicate 900 kHz). Peak T_{401} and T_{402} for a maximum S-meter reading.

Set the signal generator to 2.9 MHz (the FRG-7000 digital display should indicate 100 kHz). Peak TC_{401} and TC_{402} for a maximum S-meter reading. Repeat the above adjustments until complete tracking is accomplished.

(7) Third IF Alignment T_{404}, T_{405}

Connect a signal generator to TP_{401} and TP_{406} (ground), and set its output to 2.9 MHz (the FRG-7000 digital display should indicate 100 kHz). Peak T_{404} and T_{406} and T_{405} for a maximum S-meter reading.

(8) S-meter Sensitivity VR_{401}

Connect a signal generator to SW2, and apply an 11 MHz 100 dB signal. Tune the receiver to 11 MHz, and adjust VR_{401} for a full scale reading on the S-meter.

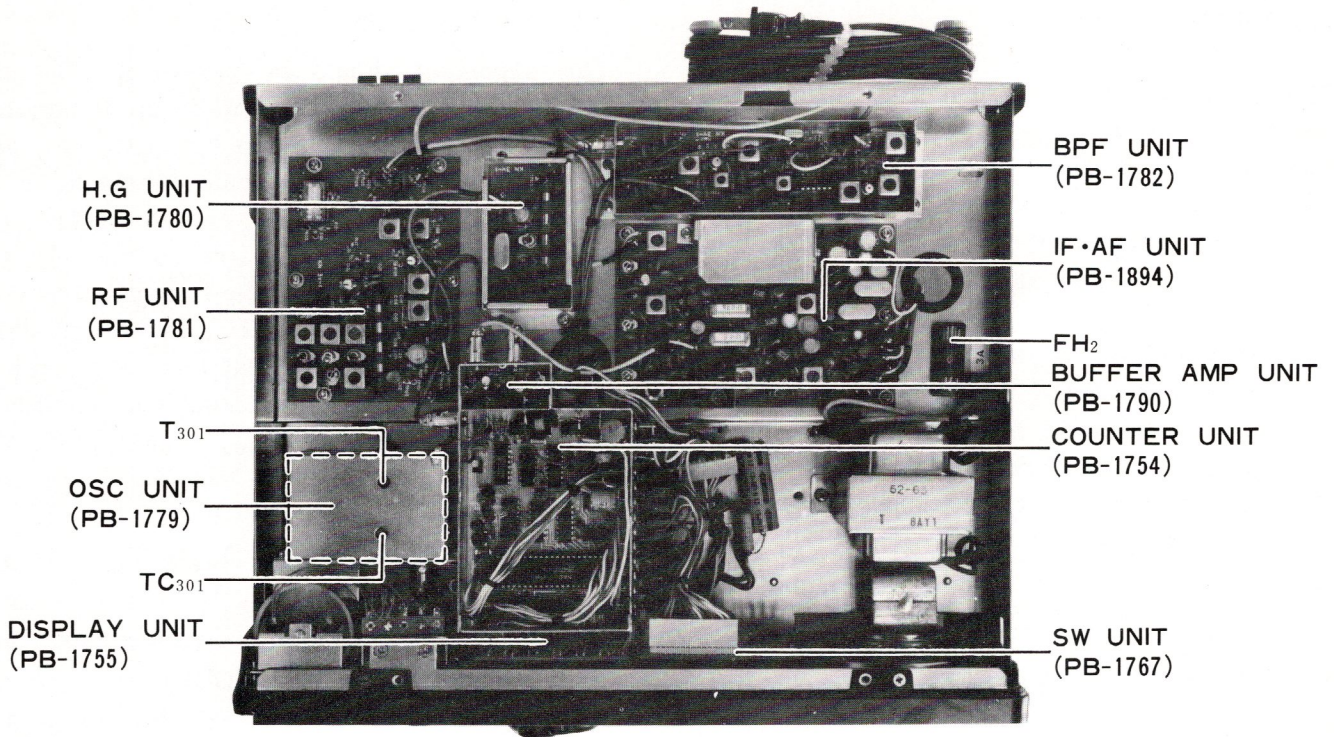

TOP VIEW

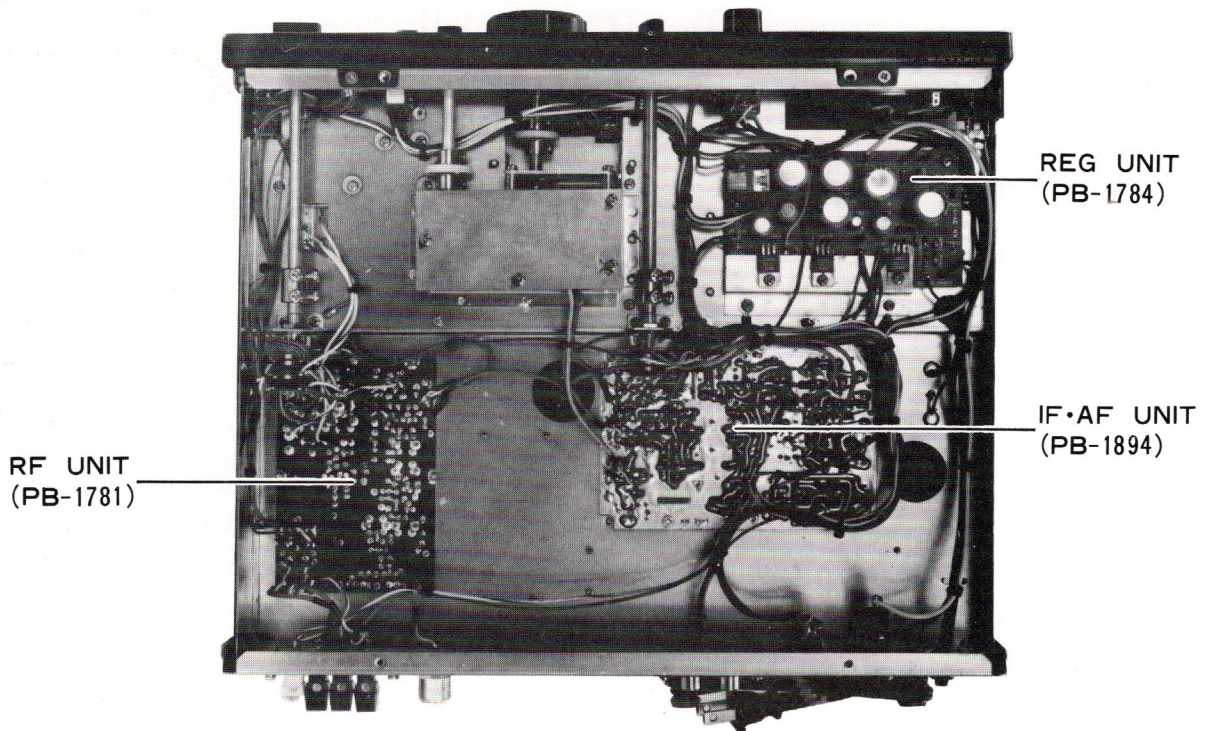

BOTTOM VIEW

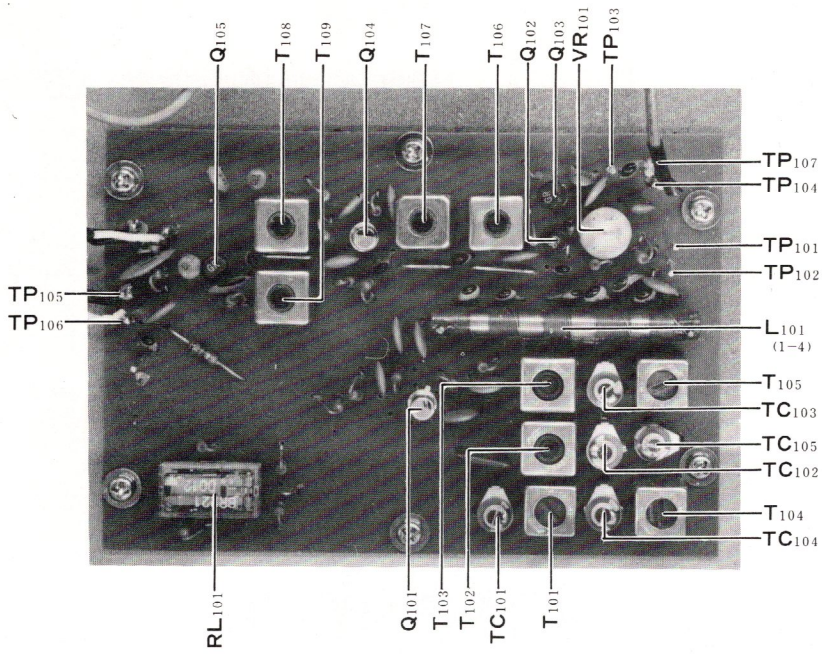

RF UNIT (PB-1781)

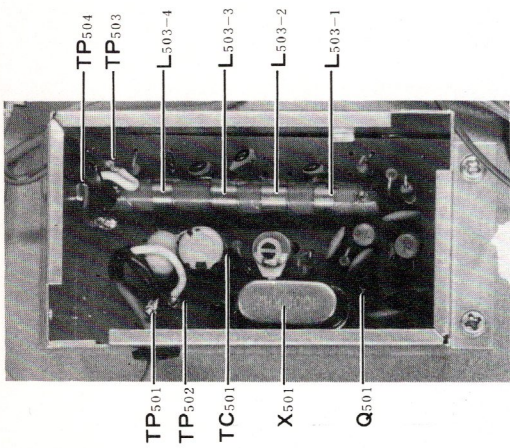

H.G. UNIT (PB-1780)

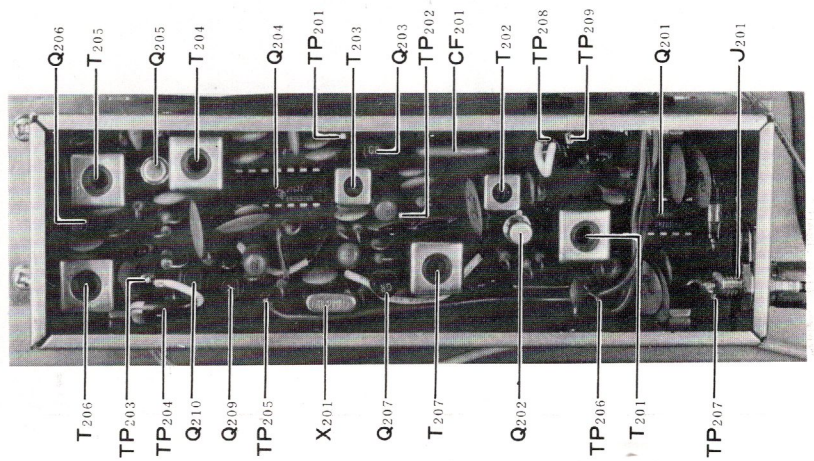

BPF UNIT (PB-1782)

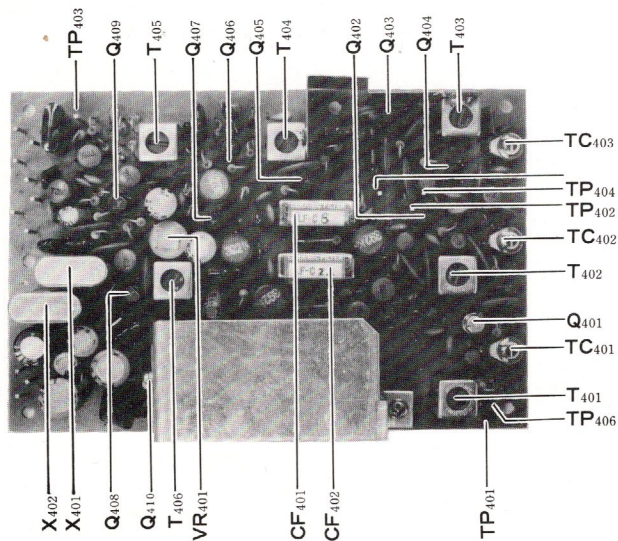

IF-AF UNIT (PB-1894)

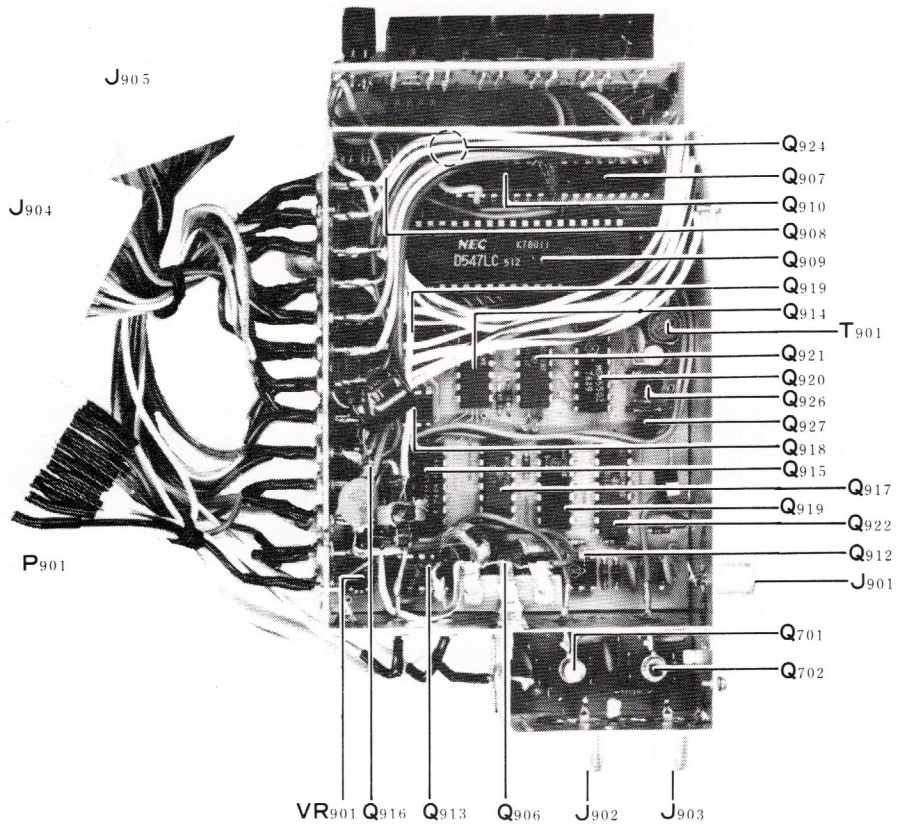

COUNTER UNIT(PB-1754)

PARTS LIST

MAIN CHASSIS						
Symbol No.	Part No.	Description				
		RESISTOR				
R5	40143470	Carbon film	1/4W VJ 47Ω			FUSE
R3, 6	41143680	" "	" TJ 68Ω	F1	73000013	1A (100V~117V)
R1	41143222	" "	" " 2.2kΩ		73000012	0.5A (200V~234V)
R2	40143223	" "	" VJ 22kΩ	F2	73000003	3A
R4	42124120	" composition	1/2W GK 12Ω			
R7, 8, 9	42124225	" "	" " 2.2MΩ			
R10	44204339	Wire wound	2W 3.3Ω			
						FUSE HOLDER
				FH1	69030005	SN-1301
				FH2	69030003	F3294
		POTENTIOMETER				
VR1	49800104	DM10A	10kΩB/10kΩB			
						PILOT LAMP
				PL1, 2, 13, 14	14000033	BQ-034-22529A
				PL3, 9~12	14000031	BQ-034-22527A
				PL4~8	14000032	BQ-034-22528A
		CAPACITOR				
C2	31820050	Ceramic disc	50WV 5PF CH			
C3	30820103	" "	" 0.01μF			
C1	36825104	Mylar	" 0.1μF			
C4	34220108	Electrolytic	25WV TT 1000μF			
						RF UNIT
				Symbol No.	Parts No.	Description
					017811AZ	RF board with components
					PB-1781A	P.C. Board
		VARIABLE CAPACITOR				
VC1, 2	39000078	CY-31A	335PF x 2			
VC3	39000079	TSN 150Sx04-1	4PF			
						FET
				Q102, 103, 105	22800195	2SK19GR
				Q104	23800401	3SK40M
				Q101	22800513	3SK51-03
		POWER TRANSFORMER				
PT1	52000062	52-62				
						DIODE
				D101	21015550	Silicon 1S1555
		METER				
M1	74000380	KTC-024				
						RESISTOR
				R121	40143100	Carbon film 1/4W VJ 10Ω
				R119	40143330	" " " " 33Ω
				R120	40143470	" " " " 47Ω
				R107, 122	40143101	" " " " 100Ω
				R102, 108, 113, 116, 124	40143221	" " " " 220Ω
		SWITCH				
S1	62000002	ESR-E365R20A		R103	41143221	" " " TJ 220Ω
S2	62000020	ESR-E264R20		R104, 105	40143561	" " " VJ 560Ω
S3	65000012	PW-22		R112	40143681	" " " " 680Ω
S4	65000038	PW-42		R115	40143152	" " " " 1.5kΩ
S5	64000053	8H2011		R110,	40143103	" " " " 10kΩ
				R111	40143273	" " " " 27kΩ
				R118	40143393	" " " " 39kΩ
				R117	40143473	" " " " 47kΩ
				R101, 106, 109, 114, 123	40143104	" " " " 100kΩ
		RECEPTACLE				
J1	68000011	M-BR-06D				
J2	68040006	SQ2450-03				
J3, 5	68020012	SG8050-07				
J4	68030002	SG7814				
J6	80043741	UP-021				

WORLD TIME CONVERSION CHART IN HOURS

Japan	Eastern Australia Melbourne, Sydney	New Caledonia New Zealand	International Date Fiji Islands	Nome, Alaska Samoa Islands	Hawaii Midway Islands	Eastern Alaska Dawson	Pacific Standard Time, Los Angeles, Seattle, Juneau	Mountain Standard Time, Calgary, Denver, Phoenix	Central Standard Time, Chicago, Costa Rica	Eastern Standard Time, Montreal, New York, Peru	Atlantic Standard Time, Nova Scotia	Greenland Rio de Janeiro, Brazil	Azores Iceland Canary Islands	GMT	Central Europe, Berlin, Geneva, Stockholm, Vienna	Eastern Europe, Moscow, Cairo, Cape Town	Arabia, Madagas- car, Ethiopia, Iran, Mauritius, Reun- ion Island	Central Russia, Bombay, India	Calcutta, Novos- ibirsk, Russia, Tibet	Sumatra, Thailand, Laos	Philippines Perth		
9AM	10AM	11AM	Noon	1PM	2PM	3PM	4PM	5PM	6PM	7PM	8PM	9PM	10PM	11PM	0000	1AM	2AM	3AM	4AM	5AM	6AM	7AM	8AM
10AM	11AM	Noon	1PM	2PM	3PM	4PM	5PM	6PM	7PM	8PM	9PM	10PM	11PM	Mid Night	0100	2AM	3AM	4AM	5AM	6AM	7AM	8AM	9AM
11AM	Noon	1PM	2PM	3PM	4PM	5PM	6PM	7PM	8PM	9PM	10PM	11PM	Mid Night	1AM	0200	3AM	4AM	5AM	6AM	7AM	8AM	9AM	10AM
Noon	1PM	2PM	3PM	4PM	5PM	6PM	7PM	8PM	9PM	10PM	11PM	Mid Night	1AM	2AM	0300	4AM	5AM	6AM	7AM	8AM	9AM	10AM	11AM
1PM	2PM	3PM	4PM	5PM	6PM	7PM	8PM	9PM	10PM	11PM	Mid Night	1AM	2AM	3AM	0400	4AM	5AM	6AM	7AM	8AM	9AM	10AM	11AM
2PM	3PM	4PM	5PM	6PM	7PM	8PM	9PM	10PM	11PM	Mid Night	1AM	2AM	3AM	4AM	0500	5AM	6AM	7AM	8AM	9AM	10AM	11AM	Noon
3PM	4PM	5PM	6PM	7PM	8PM	9PM	10PM	11PM	Mid Night	1AM	2AM	3AM	4AM	5AM	0600	6AM	7AM	8AM	9AM	10AM	11AM	Noon	1PM
4PM	5PM	6PM	7PM	8PM	9PM	10PM	11PM	Mid Night	1AM	2AM	3AM	4AM	5AM	6AM	0700	7AM	8AM	9AM	10AM	11AM	Noon	1PM	2PM
5PM	6PM	7PM	8PM	9PM	10PM	11PM	Mid Night	1AM	2AM	3AM	4AM	5AM	6AM	7AM	0800	8AM	9AM	10AM	11AM	Noon	1PM	2PM	3PM
6PM	7PM	8PM	9PM	10PM	11PM	Mid Night	1AM	2AM	3AM	4AM	5AM	6AM	7AM	8AM	0900	9AM	10AM	11AM	Noon	1PM	2PM	3PM	4PM
7PM	8PM	9PM	10PM	11PM	Mid Night	1AM	2AM	3AM	4AM	5AM	6AM	7AM	8AM	9AM	1000	10AM	11AM	Noon	1PM	2PM	3PM	4PM	5PM
8PM	9PM	10PM	11PM	Mid Night	1AM	2AM	3AM	4AM	5AM	6AM	7AM	8AM	9AM	10AM	1100	Noon	1PM	2PM	3PM	4PM	5PM	6PM	7PM
9PM	10PM	11PM	Mid Night	1AM	2AM	3AM	4AM	5AM	6AM	7AM	8AM	9AM	10AM	11AM	1200	1PM	2PM	3PM	4PM	5PM	6PM	7PM	8PM
10PM	11PM	Mid Night	1AM	2AM	3AM	4AM	5AM	6AM	7AM	8AM	9AM	10AM	11AM	Noon	1300	2PM	3PM	4PM	5PM	6PM	7PM	8PM	9PM
11PM	Mid Night	1AM	2AM	3AM	4AM	5AM	6AM	7AM	8AM	9AM	10AM	11AM	Noon	1400	3PM	4PM	5PM	6PM	7PM	8PM	9PM	10PM	
Mid Night	1AM	2AM	3AM	4AM	5AM	6AM	7AM	8AM	9AM	10AM	11AM	Noon	1PM	1500	4PM	5PM	6PM	7PM	8PM	9PM	10PM	11PM	
1AM	2AM	3AM	4AM	5AM	6AM	7AM	8AM	9AM	10AM	11AM	Noon	1PM	2PM	1600	5PM	6PM	7PM	8PM	9PM	10PM	11PM	Mid Night	
2AM	3AM	4AM	5AM	6AM	7AM	8AM	9AM	10AM	11AM	Noon	1PM	2PM	3PM	1700	6PM	7PM	8PM	9PM	10PM	11PM	Mid Night	1AM	
3AM	4AM	5AM	6AM	7AM	8AM	9AM	10AM	11AM	Noon	1PM	2PM	3PM	4PM	1800	7PM	8PM	9PM	10PM	11PM	Mid Night	1AM	2AM	
4AM	5AM	6AM	7AM	8AM	9AM	10AM	11AM	Noon	1PM	2PM	3PM	4PM	5PM	1900	8PM	9PM	10PM	11PM	Mid Night	1AM	2AM	3AM	
5AM	6AM	7AM	8AM	9AM	10AM	11AM	Noon	1PM	2PM	3PM	4PM	5PM	6PM	2000	9PM	10PM	11PM	Mid Night	1AM	2AM	3AM	4AM	
6AM	7AM	8AM	9AM	10AM	11AM	Noon	1PM	2PM	3PM	4PM	5PM	6PM	7PM	2100	10PM	11PM	Mid Night	1AM	2AM	3AM	4AM	5AM	
7AM	8AM	9AM	10AM	11AM	Noon	1PM	2PM	3PM	4PM	5PM	6PM	7PM	8PM	2200	11PM	Mid Night	1AM	2AM	3AM	4AM	5AM	6AM	
8AM	9AM	10AM	11AM	Noon	1PM	2PM	3PM	4PM	5PM	6PM	7PM	8PM	9PM	2300	Mid Night	1AM	2AM	3AM	4AM	5AM	6AM	7AM	

